

Model DC68CM

Extruded Aluminum Louver • 6" Deep • 35° Straight Blades • Combination Adjustable • Concealed Actuator

STANDARD CONSTRUCTION

- FRAME:** .081" thk. (nominal) extruded aluminum, 6063-T52/T6 alloy. Channel type.
- BLADES:** Stationary blades are made from .081" thk. (nominal) extruded aluminum 6063-T52/T6 alloy. Adjustable blades are made from .125" thk. (nominal) extruded aluminum 6063-T52/T6 alloy. Blades are approximately 4½" on centers.
- LOUVER FACE:** Full width sill with head and blades contained within jambs.
- SHAFT:** .50" dia. aluminum "Pin-Lock" rod.
- BEARINGS:** Celcon bearing material so that there will be no metal to metal friction.
- LINKAGE:** Extruded aluminum, concealed in the channel out of the airstream. The pivots, which rotate in Celcon bearings, are .50" dia. plated and machined steel. The 5/16" dia. aluminum linkage rod is locked to the pivot by a ¼ - 20 set screw with epoxy locking patch.
- SEALS:** Extruded silicone rubber seals at blade edge. Foam on bottom blade. Stainless steel at jambs.
- SCREEN:** (When indicated, in a removable frame) ½" flattened aluminum, .051" thk.,
 -or- Insect screen 19/16 aluminum mesh, .011" dia.,
 -or- ½" sq. mesh intermediate double crimped aluminum wire, .063" dia.
- FINISH:** Mill.
- ACTUATOR:** 120 VAC, spring return normally closed.
133 in-lbs. torque.

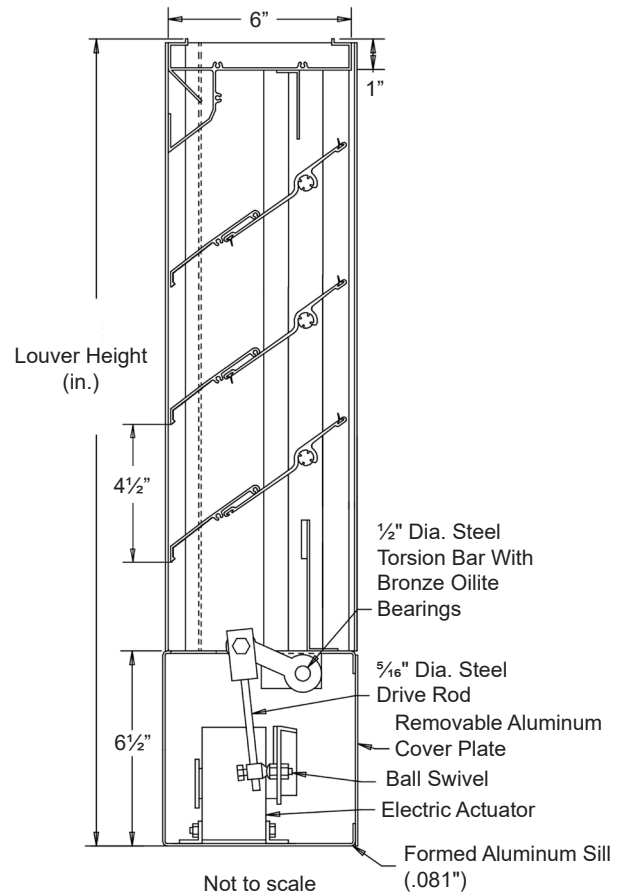

OPTIONS

Finishes - Enamels, Epoxies, etc.
Other screens available.

NOTES

1. Nominal deductions will be made to the opening size given.
2. Approximate shipping weight is 5.0 lbs./sq.ft.

LOUVER SIZES

Min Panel	Max Single Panel
12"W x 19"H	48"W x 96"H

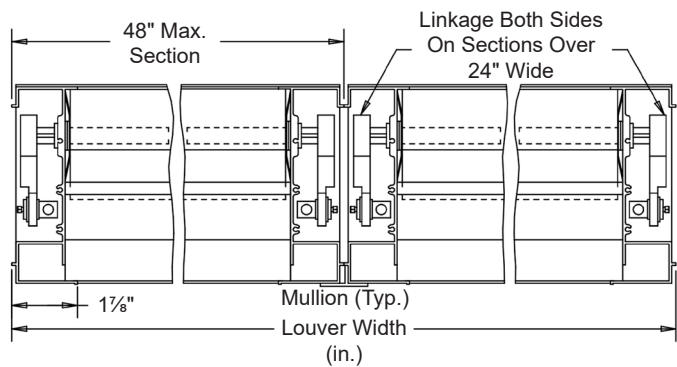

Item #	Qty	Width	Height	Width	Height	Mullion	Type	Location	Union Made
		Opening Size		Louver Size			Screens		
Arch. / Eng. :						EDR:		ECN:	Job:
Contractor:									
Project:						Date:		DWN:	DWG:

In the interest of product development, Louvers & Dampers reserves the right to make changes without notice.